

MEMO 801
DTF 120 / DTS 120
TECHNICAL SPECIFICATIONS

Dato: 16.08.2012
Siste rev.: 25.05.2016
Dok. nr.: K4-10/1E

Sign.: sss
Sign.: tb
Control: ps

TECHNICAL SPECIFICATIONS

DIMENSIONS AND CROSS-SECTION PARAMETERS UNIT

Inner tube:

DTS120: CFRHS 100x50x6, L=400mm. Cold formed, S355. Used on edge.

DTF120: CFRHS 100x50x6, L=425mm. Cold formed, S355. Used on edge.

Plastic section modulus on edge: $W_{pl}=46900\text{mm}^3$

Cross section area: $A=1560\text{mm}^2$

Shear area: $A_v=A \times h / (b+h) = 1560 \times 100 / (50+100)$
 $=1040\text{mm}^2$ EC3, Clause 6.2.6

Outer tube:

DTS120: Thin steel plate (1mm) with PVC end cap. L=450mm. Internal dimensions: 105x55.

DTF120: Without outer tube.

Half round steel:

DTS120: Diameter $\varnothing=76\text{mm}$, Length=100mm, S275.

DTF120: Diameter $\varnothing=76\text{mm}$, Length=100mm, S275.

Additional steel plate at back:

DTS120: $b \times t \times l = 60 \times 10 \times 60$, S355.

DTF120: Without steel plate at back.

Additional steel plate welded to upper flange in front (locking plate):

DTS120: $b \times t \times l = 30 \times 3 \times 40$, S355.

DTF120: Without locking plate in front.

LOADS DTF120/DTS120

Vertical ultimate limit state load: $F_V = 120\text{kN}$.

Horizontal ultimate limit state load in transverse direction: $F_T = 0\text{kN}$.

Horizontal ultimate limit state load in axial direction: $F_H = 0\text{kN}$.*)

*) The hollow core profile of the unit is designed for a vertical load in combination with a horizontal load equal to 15% of the ultimate limit state vertical load: $\Rightarrow F_H = 0,15F_V = 18\text{kN}$.

IMPORTANT!

The anchoring of the DTF/DTS120 unit in the pre-cast element is not designed to transfer the horizontal force that may occur due to friction at the support, and may be introduced in the joint due to creep, shrinkage etc. in the pre-cast elements. Use and utilization of the DTF/DTS120 is therefore only acceptable in joints where all possible horizontal forces are transferred via other connections. However, with respect to cross-section integrity of the DTF/DTS120 hollow core profile, this profile is designed for the vertical ultimate limit state load in combination with a horizontal load equal to 15% of the vertical load.

A 70mm long shim should always be used on the support, with a fixed location 5mm from the edge of the supporting element, see Figure 3. This shim will give a distributed load on the unit, and ensure the centre of load is located maximum 75mm from the edge of the DT. The width of the shim is recommended minimum 70mm. The thickness is selected based on the vertical tolerances on support.

SPECIFICATIONS DTF120

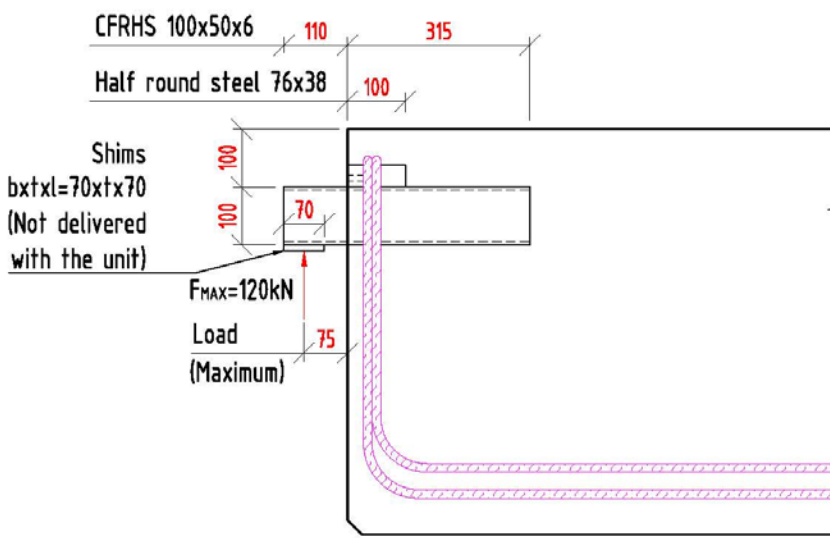

Figure 1: DTF120.

SPECIFICATIONS DTS120

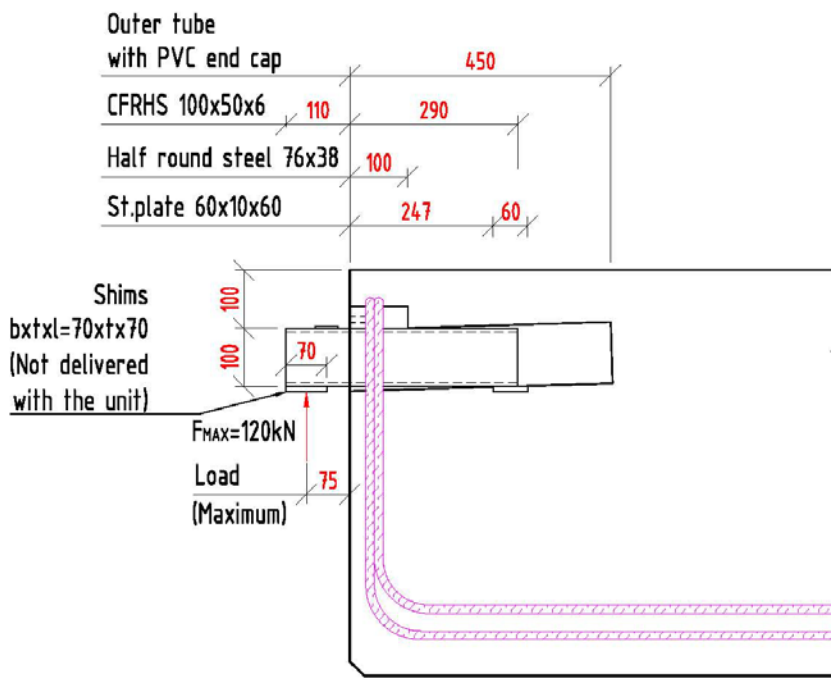

Figure 2: DTS120.

TOLERANCES AND SOLUTION AT THE SUPPORT

The unit is designed with the hollow core tube cantilevering 110mm and with a maximum of 75mm to the centre of the load. (The 110mm is a fixed length for the DTF, while a safety device on the DTS-unit ensures the inner tube is not extracted beyond 110mm.) A 70mm long shim with a fixed location 5mm from the edge of the supporting element should always be used on the support. The fixed location of the shim ensures the design assumption with respect to centre of load is fulfilled for the specified tolerances on gap between the elements. The tolerances are stated below and illustrated in Figure 3.

The nominal gap and tolerances are: 20mm ±15mm.

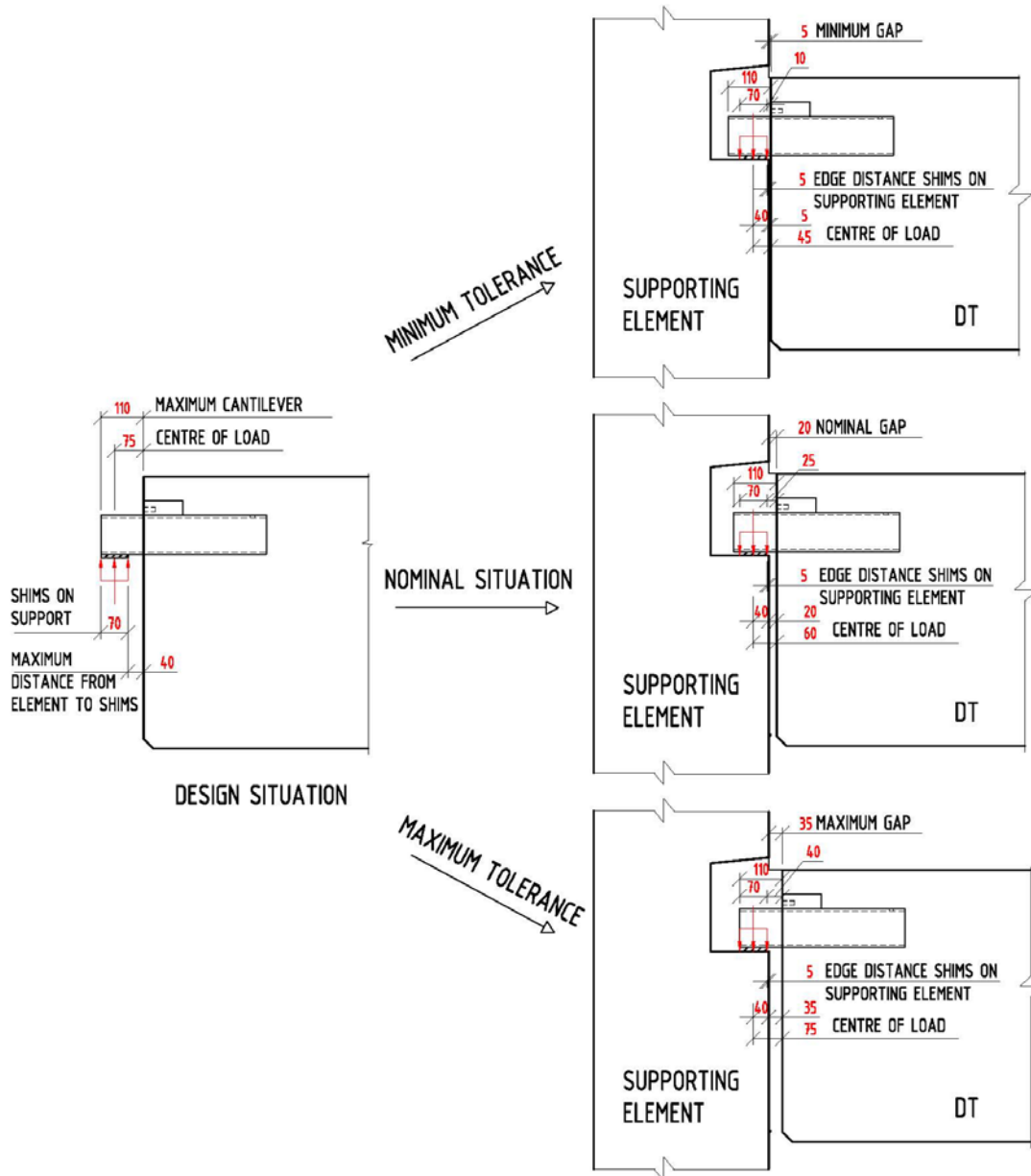

Figure 3: Tolerances. (Both DTF and DTS)

The specified shim on the support will not be sufficient to ensure distribution of the reaction force into the concrete in the supporting element in a proper way. Thus, this issue has to be dealt with and solved on a case to case basis. One way of designing the support is by embedding a thick steel plate in the supporting element. This solution is illustrated in Figure 4 and documented in the following calculations.

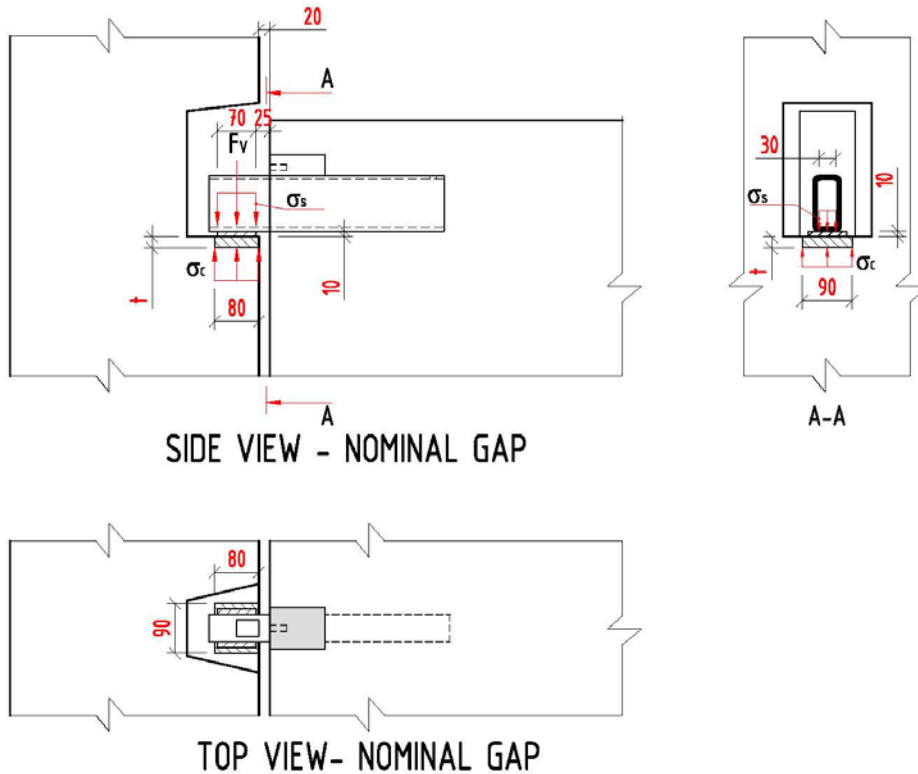

Figure 4: Solution at the support.

I: Stress at support from unit:

$$\sigma_s = \frac{120kN}{70mm \times 30mm} = 57,2MPa$$

II: Required concrete area (assuming $f_{cd}=17MPa$):

$$A_c = \frac{120kN}{17MPa} = 7059mm^2$$

Assuming shims 5 mm from the edge \Rightarrow Symmetry around the centre of the load gives the effective length of the steel plate as: $l = 80mm$

\Rightarrow Select width of steel plate area $b = 7059/80 = 89mm \Rightarrow$ Select $b = 90mm \Rightarrow A = 90 \times 80 = 7200mm^2$

III: Uniform concrete stress beneath steel plate:

$$\sigma_c = \frac{120kN}{7200mm^2} = 16,7MPa$$

IV: Bending moment in centre of steel plate.

The steel plate is assumed to bend about an axis longitudinal to the axial direction of the unit:

$$\begin{aligned} M_{Ed,plate} &= 16,7MPa \times (90mm)^2 / 8 \times 80mm \\ &= 1352700Nmm \end{aligned}$$

V: Required thickness of steel plate (assuming steel grade S355 and $f_{yd}=322MPa$):

$$t = \sqrt{\frac{6 \times M}{l \times f_{yd}}} = \sqrt{\frac{6 \times 1352700mm}{80mm \times 322MPa}} = 17,8mm$$

⇒ Select: t=20mm.

⇒ Selected support plate: bxlxt=90x80x20

REQUIREMENTS TO DT-DIMENSIONS AND RECESS AT THE SUPPORT

Due to the variety of cross sections, and different standard reinforcement solutions, it has to be evaluated on a case to case basis if the unit will fit into the DT element with a suitable reinforcement. However, some minimum requirements to the cross section of the DT are listed below and illustrated in Figure 5.

The minimum width of the web at top (W1) is found based on the requirements in front of the DT at the level of the unit. The maximum width at bottom (W2) is based on a minimum inclination of the compression strut from the corner of the stirrup to the corner of the unit. This is recommended not to be less than 3/2 as illustrated in Figure 5. This requirement is essential for recommending use of the normal DT shear stirrups to carry the reaction force from the back of the unit. The requirement leads to a ratio between H and W2 at bottom of the DT that usually is fulfilled in normal DT-cross sections. As a minimum, the height H below the bottom of the unit shall not be less than 100mm.

The recess in the supporting element must ensure easy access for proper grouting of the joint after mounting of the elements. The depth of the recess is recommended at least 130mm to account for the tolerances on gap between the elements.

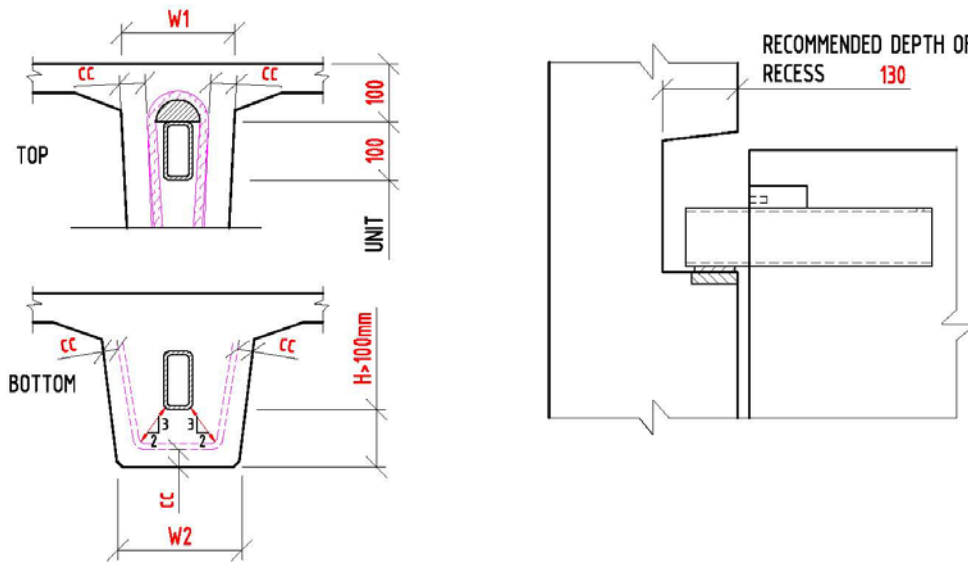

Figure 5: Requirements to the DT-element. (Both DTF and DTS)

1) Minimum width of DT at the level of the unit:

$$W1 = \text{Width of half round steel} + 2 \times \varnothing 12 \text{ bars} + 2 \times \text{concrete cover}$$

Assume concrete cover: 20mm

$$\Rightarrow W1 = 76 + 2 \times 15 + 2 \times 20 = 146 \text{ mm}$$

2) Ratio between H and W2:

$$W2 < 4/3H + 50$$

3) H minimum = 100mm